

Séries
DSX

SIZE 9 COAXIAL PIN CONTACT
FOR RG180 AND RG195 CABLES

Issue:
21 SEPT.94

Page
1 / 1

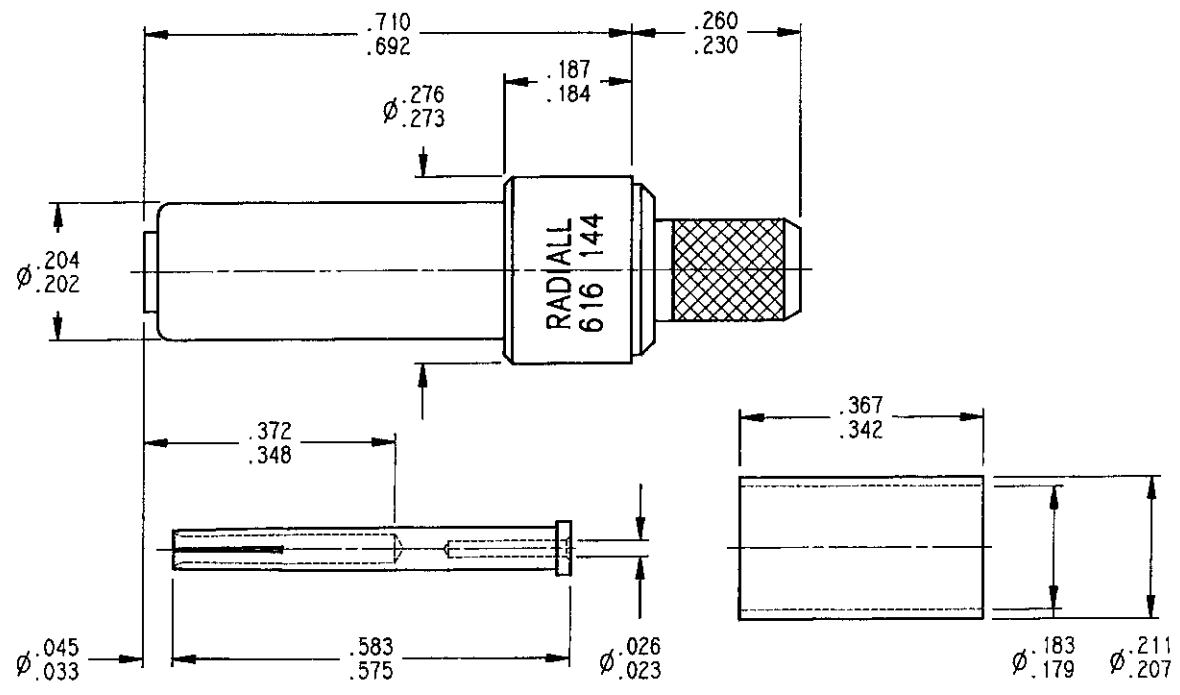

MATERIAL AND FINISH:
 OUTER CONTACT: BRASS_GOLD OVER NICKEL PLATED
 INSULATOR: PTFE
 CENTER CONTACT: BERYLLIUM COPPER_GOLD OVER NICKEL PLATED
 FERRULE: ANNEALED BRASS_GOLD OVER NICKEL PLATED

ELECTRICAL CHARACTERISTICS
 IMPEDANCE: 50 Ω
 DIELECTRIC WITHSTANDING VOLTAGE: 750 Vrms
 INSULATION RESISTANCE: $\geq 5000M\Omega$
 CONTACT RESISTANCE PER CONTACT: $\leq 5m\Omega$
 VSWR: 1.3 FROM DC TO 1500MHz

WIRING INSTRUCTIONS

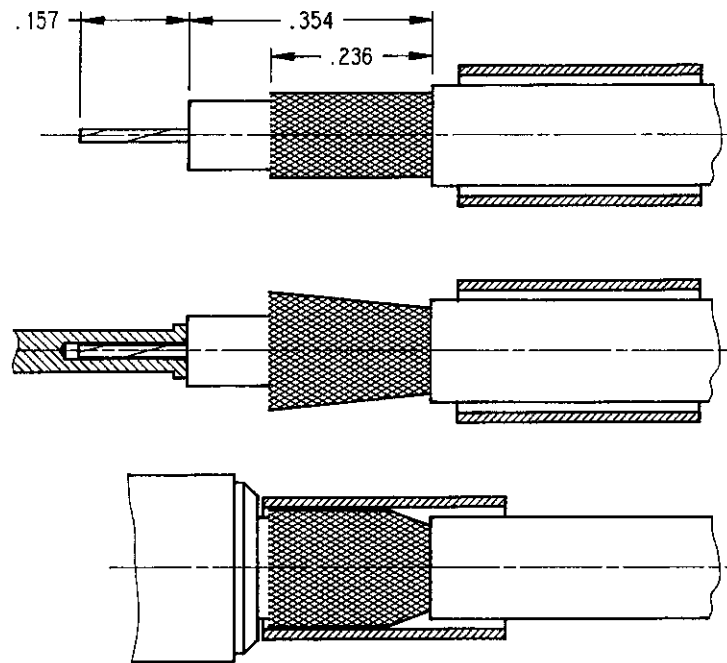

STEP 1
 TRIM BRAID, DIELECTRIC AND CENTER CONDUCTOR TO DIMENSIONS INDICATED
 SLIDE THE FERRULE ON THE CABLE

STEP 2
 INTRODUCE CENTER CONDUCTOR INTO CENTER CONTACT
 CRIMP CENTER CONTACT
 CRIMPING TOOL: M22520/2-01 SELECTOR ON 6
 POSITIONER: 282574

STEP 3
 SLIDE CENTER CONTACT INTO THE OUTER CONTACT, ENSURING THAT IT'S PUSHED HOME AND THAT THE REAR KNURLED BARREL IS UNDER THE BRAID
 SLIDE THE FERRULE OVER THE BRAID AND CRIMP
 CRIMPING TOOL: M22520/5-013
 DIE: M22520/5-05 HEX B

This information is given as an indication, in the continual goal to improve our products, we reserve the right to make any modifications judged necessary.

CREATION				
PEN: .				
NOM: JP MACARI				
DATE: 21 SEPT.94				
APPR.: <i>Desloved</i>				
Issue	Revisions	Name	Approved	